

Pallet Forks & Frame

Compact Tractor Pallet Forks & Frame

CID compact tractor pallet forks are designed specifically for compact tractors. A lightweight frame offers 2000 lb. load capacity. Fork tines are 42" in length, while see through visibility eases tine placement. Hooking up is fast and convenient with a universal skid steer mount.

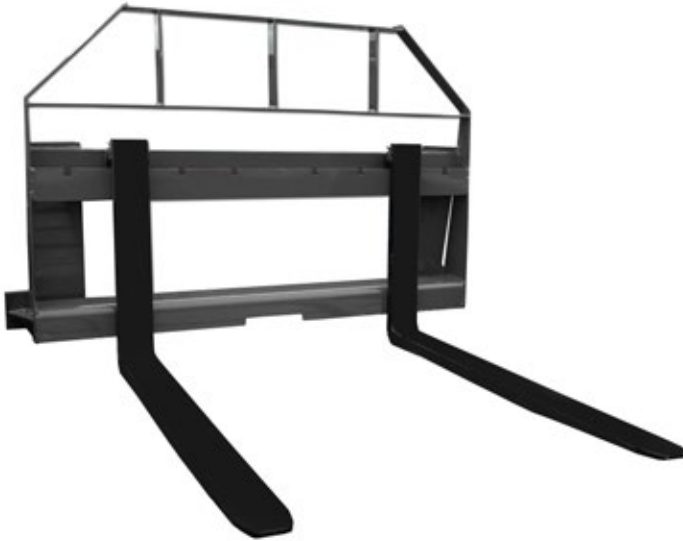

- Heat treated American made forks
- 2000 lb. load capacity
- 48" tines available
- Euro style and John Deere mounts are available

Standard Duty Pallet Forks & Frame

Anyone that owns a skid steer should have a set of forks on hand. Forks are ideal for lifting pallets, loading lumber or just about anything else. Our forks are 1-1/4 inches thick, 4 inches wide and 42 inches long. They are completely heat treated and rated to carry 3,000 lbs. We put a step on both sides of our frames so the operator can easily climb into the cab. Euro Style and John Deere mounts are available.



- Heat treated American made forks
- Rated to carry 3,000 lbs.
- Steps on both sides of frame
- Euro style and John Deere mounts are available
- 48" tines available

Compact Tractor Pallet Forks & Frame Specs

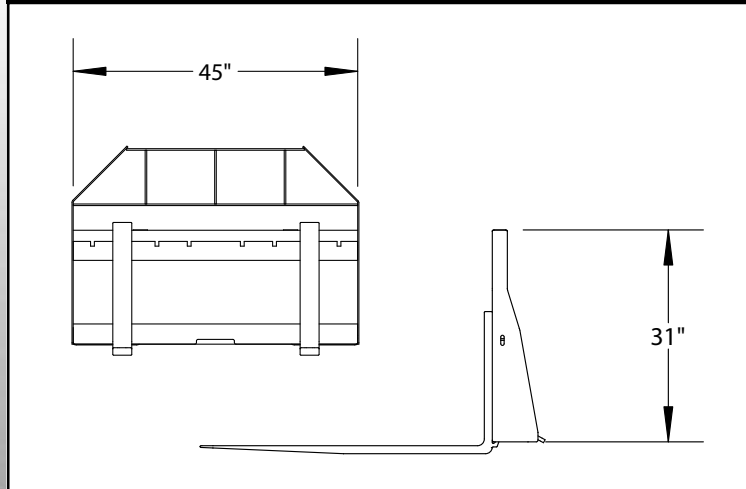

Standard Duty Pallet Forks & Frame Specs

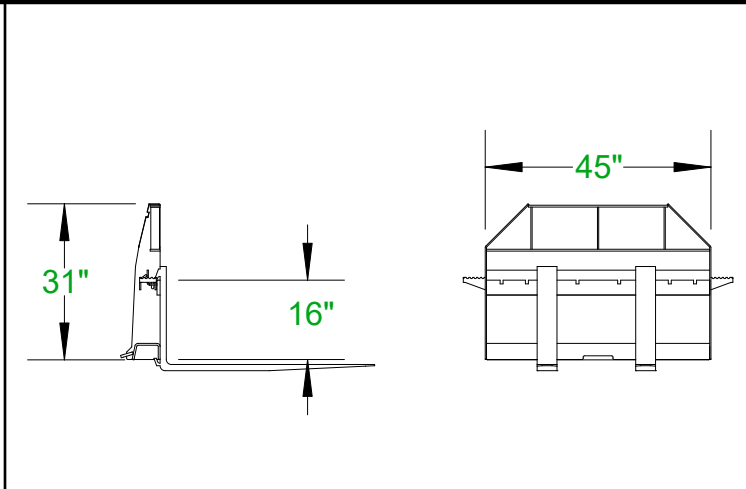

Heavy Duty Pallet Forks & Frame - Hydraulic Pallet Forks & Frame



Anyone that owns a skid steer should have a set of forks on hand. Forks are ideal for lifting pallets, loading lumber or just about anything else. Our forks are 1-3/8 inches thick, 4 inches wide and 48 inches long. They are completely heat treated and rated to carry 4,000 lbs. We put a step on both sides of our frames so the operator can easily climb into the cab. Euro Style and John Deere mounts are available.

- Heat treated American made forks
- Rated to carry 4,000 lbs.
- Optional 5,500 lbs. capacity available
- Steps on both sides of frame
- Euro style and John Deere mounts are available
- Optional name in grill
- 42", 48", 60", 72" tines available

Heavy Duty Pallet Forks & Frame Specs

Hydraulic Pallet Forks & Frame Specs

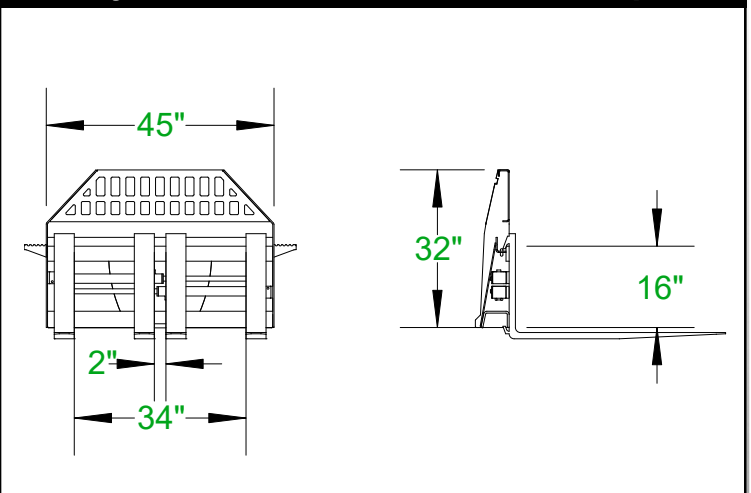
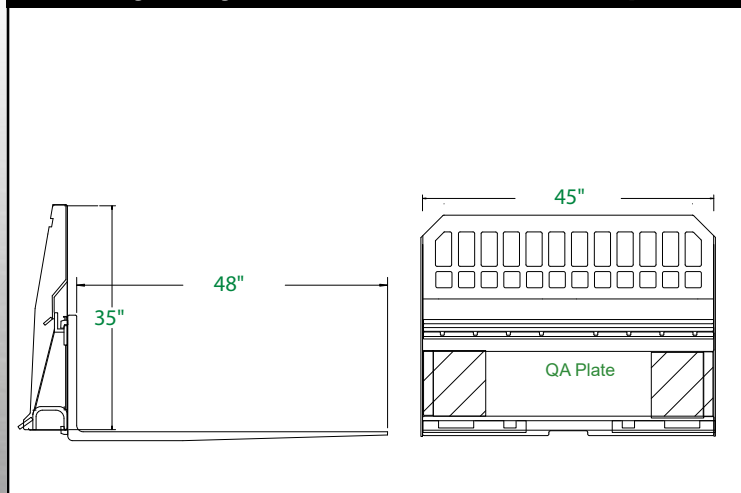

Heavy Duty Walk Through Pallet Forks & Frame



If you own a skid steer, you should have a set of forks on hand. Our walk through frame is exactly what it says. Instead of having to climb around or over the fork back frame, simply walk through it. This added convenience will make jobs go faster and easier whether you are lifting pallets, loading lumber or just about anything else. Our forks are 1-3/8 inches thick, 4 inches wide, completely heat treated, 48 inches long and rated to carry 4,000 lbs.

- Walk through design makes entering machine easier
- Heat treated American made forks
- Rated to carry 4,000 lbs.
- Steps on both sides of frame
- Euro style and John Deere mounts are available
- 42", 48", 60", 72" tines available
- Optional 5,500 lbs. capacity

Heavy Duty Walk Through Pallet Forks & Frame Specs

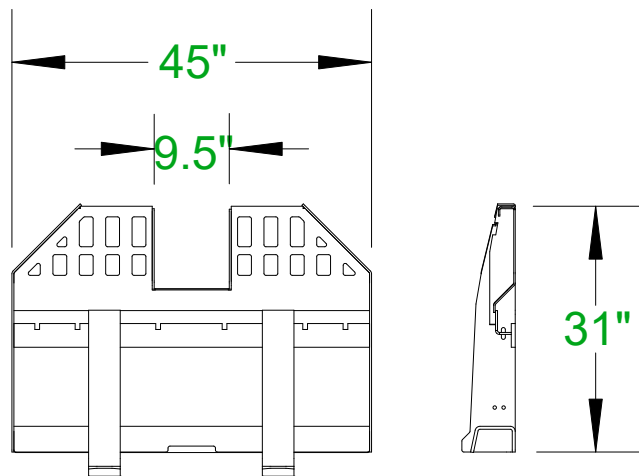

X-treme Pallet Forks & Frame



Anyone that owns a skid steer should have a set of forks on hand. Forks are ideal for lifting pallets, loading lumber or just about anything else. Our forks are 1-3/4 inches thick, 5 inches wide and 48 inches long. They are completely heat treated and rated to carry 8,000 lbs. We put a step on both sides of our frames so the operator can easily climb into the cab. Euro Style and John Deere mounts are available.

- Heat treated American made forks
- Rated to carry 8,000 lbs.
- Steps on both sides of frame
- Euro style and John Deere mounts are available
- Available sizes: 48", 60", 72"

X-treme Pallet Forks & Frame Specs

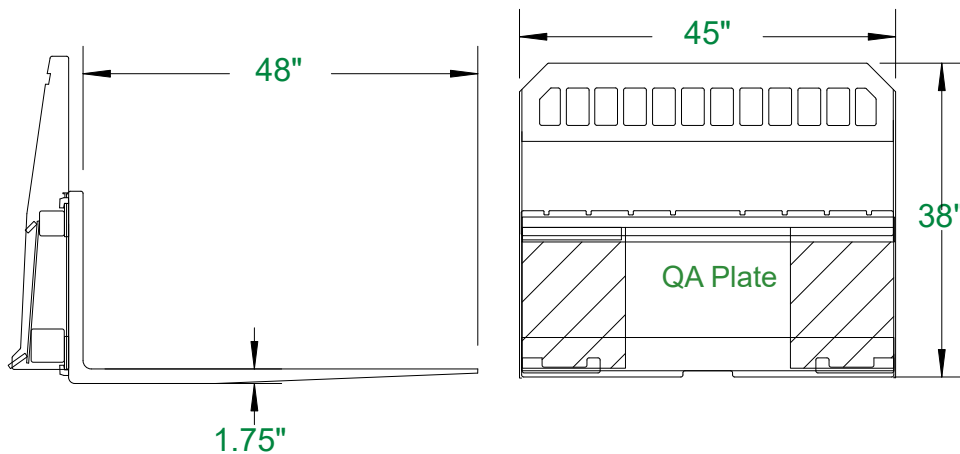

X-treme Fork Grapples

X-treme Fork Grapple

Our Fork Grapple is ideal for use on the farm, in logging operations and by general contractors. The top tine is adjustable for small or large loads and the hydraulic cylinder gives you plenty of clamping force. Our fork tines are completely heat treated from the tip to the heel and made in the U.S.A.



Class 2 shown

- Heat treated American made forks
- Adjustable top tine to handle any size load
- 2" x 12" cylinder
- Available with 48", 60", 72" tines
- Class 3 Optional

X-treme Fork Grapple Specs

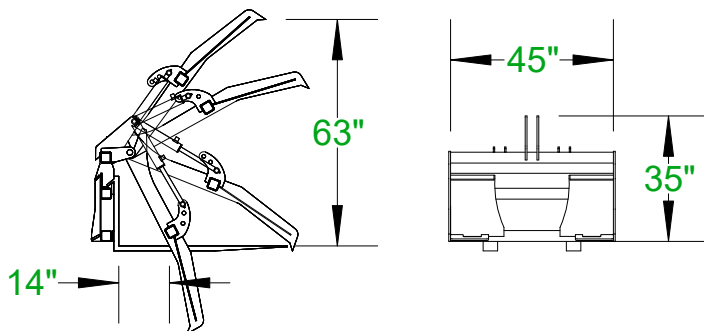

X-treme Mat Grapple

Our x-treme mat grapple is designed to pick up and move equipment mats. It can also be used to transport logs, poles and just about anything else. We build this in a class 3 carriage with a lifting capacity of 8,000 pounds.



- Heat treated American made forks
- Designed to lift equipment mats
- Teeth on the grapple to grip the mats
- 60" forks standard
- 48", 72" forks optional

X-treme Mat Grapple Specs

